



# **iRIS 120**

## **User Guide**

**For Software  
Version: V1.00**

Requires Firmware  
Version: V1.00+

Amendments:

Issue 1:           Version 1.00

16<sup>th</sup> May 2005

Disclaimer

Under no circumstances will iQuest (NZ) Ltd be liable or responsible for any consequential damage or loss that may arise from the use of this product.

All examples and diagrams shown in this manual and any supplied software examples are intended as a guide to understanding this product, not to guarantee operation. iQuest (NZ) Ltd accepts no responsibility for use of this product based on this information or these examples.

Owing to the wide variety of possible applications of this product, you must satisfy yourself as to its suitability to your specific application.

© 2005, iQuest (NZ) Ltd  
All rights reserved.

This publication, or any part of it, and any software accompanying it may not be copied, photocopied, reproduced, translated or communicated to any third party, or reduced to electronic medium without prior written permission from iQuest (NZ) Ltd.

# Contents

<b>1 Introduction</b> .....	<b>1</b>
1.1 About this Manual.....	1
1.2 Support.....	1
<b>2 Overview</b> .....	<b>2</b>
2.1 Introduction .....	2
2.2 General Characteristics.....	2
Feature Summary.....	3
2.3 Typical Applications.....	3
2.4 Technical Specifications.....	4
2.5 Key Features.....	5
2.5.1 Terminal Configuration.....	5
2.5.2 Data Logging.....	5
2.5.3 Logged Data Array Identification.....	5
2.5.4 Alarm Processing.....	6
2.5.5 Real Time Clock & Calendar.....	6
2.5.6 Security.....	6
<b>3 Installation</b> .....	<b>7</b>
3.1 I/O Cable .....	7
3.1.1 Internal Lithium Battery.....	7
3.1.2 External Power Supply.....	7
3.1.3 Analogue Inputs.....	7
3.1.4 Digital Inputs.....	8
3.1.5 Digital Output.....	9
3.2 Mounting .....	9
<b>4 Configuration</b> .....	<b>10</b>
4.1 Terminal Connection .....	10
4.2 Terminal Cfg.....	11
4.3 Terminal Menus.....	13
4.3.1 Main Menu (Level 1).....	13
4.3.2 Sensor Selection (Level 2).....	15
4.3.3 Sensor Cfg (Level 3).....	15
4.3.4 Alarm Selection (Level 4).....	18
4.3.5 Alarm Cfg (Level 5).....	18
4.3.6 Output Cfg (Level 2).....	19
Typical Scheduled Output Example .....	20
<b>5 Operation</b> .....	<b>21</b>
5.1 LCD & Keypad.....	21
5.1.1 LCD Operation.....	21
5.1.2 Status Icons.....	21
5.1.3 Touch Pad .....	21
5.1.4 Display Menu Structure.....	21
5.1.4.1 Title .....	22
5.1.4.2 System Status .....	22
5.1.4.3 I/O Summary .....	22
5.1.4.4 Sensor Status.....	22
5.1.4.5 Total Screen (DI1).....	23
5.1.4.6 Total Screen (DI2).....	23
5.1.4.7 Reset Totals Screen.....	23
5.2 General Hints .....	24
5.3 Dormant State .....	24

<b>6 Sensor Connection Examples</b> .....	<b>25</b>
6.1 <i>Connecting a Flow Meter or Rain Gauge</i> .....	25
6.2 <i>Connecting a 0-5V Pressure Transducer</i> .....	26
6.3 <i>Connecting a 2-Wire Loop-Powered 4-20mA Sensor</i> .....	27
6.4 <i>Connecting an Up/Down Water Level Instrument</i> .....	28
<b>7 Troubleshooting</b> .....	<b>29</b>
7.1 <i>The LCD display is blank</i> .....	29
7.2 <i>The menu option for resetting totals is not available</i> .....	29
<b>8 User Notes</b> .....	<b>30</b>
<b>9 Appendix A – Transistor Output Switch</b> .....	<b>31</b>

# 1 Introduction

## 1.1 About this Manual

This manual is intended as a detailed guide for iRIS 120 installation, configuration and operation.

This manual is also available online in Adobe Acrobat® pdf format for registered users at [www.iquest.co.nz](http://www.iquest.co.nz)

**NOTE:** *The term “iRIS” is used throughout this manual in all references to the iRIS 120.*

## 1.2 Support

Technical support for the iRIS 120 is available by contacting:

iQuest (NZ) Ltd  
P.O Box 15169  
Hamilton  
NEW ZEALAND

Tel: +64 7 857-0810  
Fax: +64 7 857-0811  
Email: [support@iquest.co.nz](mailto:support@iquest.co.nz)

For latest information and software updates, visit the iQuest (NZ) Ltd web site at [www.iquest.co.nz](http://www.iquest.co.nz)

## 2 Overview

### 2.1 Introduction

The iRIS 120 (iQuest **R**emote **I**nformation **S**ource) has been designed as a cost effective, low power, self contained datalogger for use in a wide range of data gathering and logging applications.

### 2.2 General Characteristics

The iRIS is supplied in a completely sealed plastic enclosure filled with epoxy resin. Connections are available through a one-metre multi-core cable with attached terminal strip. A small LCD provides the user display and user input is via a capacitive touch sensor that detects a finger press with no electrical or mechanical contact.

The iRIS supports a maximum of four virtual sensors, the sources of which can be chosen from a range of physical digital or analogue types. Each sensor has two associated alarms, each with separate trigger and reset levels. Each alarm also has a duration, which is used to delay the alarm trigger for analogue inputs and to determine the time over which pulse input counters should be totalised (rainfall, flow meter pulse etc). Data is logged in a four word (8 byte) compressed format which includes full date and time to fractions of a second.

The alarm(s) can be linked to the digital output to activate external equipment when one or more alarms are activated in the event of alarm activation.

---

## Feature Summary

The iRIS 120 has the following features:

- IP65 rating
- LCD and touch pad
- 1m multi-core I/O cable with screw terminal block.
- RS-232 interface
- 4 simultaneous logging channels (virtual sensors)
- 2 digital inputs (pulse, frequency, counter)
- 2 analogue inputs (0-5V, 4-20mA (with external resistor))
- 1 digital output (open drain pull-down)
- 2 alarm setpoints per logging channel
- Internal 3.6V lithium battery

## 2.3 Typical Applications

The iRIS can be used for a wide range of diverse applications, including but not limited to:

- Rainfall measurement
- Water / power / gas metering
- Remote control
- River level monitoring
- Wind measurement
- Mobile temperature monitoring
- Irrigation monitoring / control

## 2.4 Technical Specifications

<i>Dimensions:</i>	83mm x 53mm x 31mm (3.26in x 2.08in x 1.22in) (Excluding RS232 connector)
<i>Mass:</i>	320g (11.4oz)
<i>Power Supply:</i>	Internal 3.6V 2200mA/Hr lithium battery. External 5-15V dc power supply can be connected. Internal battery is disconnected when the external supply present.
<i>Comms Interface:</i>	1x RS232 DB9, DTE configuration. Fixed speed - 38400 bps.
<i>Digital I/O:</i>	2 x Digital Inputs - 30Vdc maximum input, switch to 0Vdc to activate. - Maximum input frequency 5kHz.  1 x Digital Output - Open drain pull-down (max 300mA @ 30V)
<i>Analogue I/O:</i>	2 x 12 bit uni-polar analogue inputs. Range 0-5000mV. Input impedance approx 100k $\Omega$ . Referenced to 0V common. External resistor required for current input.
<i>Logging Memory:</i>	Non-volatile 2MB flash storage of up to 250,000 time/date stamped data points. Circular buffer mode (oldest data is overwritten when the buffer is full).
<i>Clock/Calendar:</i>	Non-volatile with integral lithium battery. Clock is fully Y2K compliant with leap year recognition. Accurate to +/-20 secs month.
<i>Environmental:</i>	Storage Temperature: -20°C - +85°C. (-4°F - +185°F) Operating Temperature: -10°C - +70°C. (14°F - +185°F)

## 2.5 Key Features

### 2.5.1 Terminal Configuration

All configuration and set-up parameters are modified via a standard ASCII terminal connected to the RS232 serial interface. This means that the user can configure the device without needing to have specialised configuration software installed on their computer specifically for this purpose. Refer to Section 4.2 for details on the terminal configuration.

### 2.5.2 Data Logging

The iRIS supports the logging of data from four virtual sensors. Each of the four virtual sensors can obtain information from one of the following ten data sources:

- Analogue Input 1
- Analogue Input 2
- Pulse Counter attached to Digital Input 1
- Pulse Counter attached to Digital Input 2
- Simulated Pulse Counter enabled by Digital Input 1
- Simulated Pulse Counter enabled by Digital Input 2
- Frequency Counter attached to Digital Input 1
- Frequency Counter attached to Digital Input 2
- Up/down Counter attached to Digital Inputs 1 & 2
- Database location (data obtained from special script)

Each sensor can be set up to scale the raw data source into engineering units through the application of a multiplier and offset (slope and constant). The scaled value can be logged to non-volatile memory up to once per minute or immediately in event mode for pulse inputs. As all logged data is stored in integer format, a logging multiplier can be applied to the scaled value to maintain resolution.

It is also possible to configure a sensor to also log minimum, maximum, standard deviation or a calculated flow rate (pulse source only) values. Refer to the following descriptions in Section 2.5.3 and also Section 4.3.3 for further detail on configuring these extended logging features as part of the Sensor Cfg menus.

### 2.5.3 Logged Data Array Identification

Each sensor's logged data is identified by an array ID number. For the primary logged data, the ID is the sensor number itself. For the optional supplementary data (min/max/deviation/flow), the array ID has an offset added to the sensor number that it is derived from. These ID offsets are as follows:

Minimum:	+10
Maximum:	+20
Deviation:	+30
Flow Rate	+40

For example, Sensor 4 has been configured to log the average value, plus the maximum and standard deviation. Three data arrays will be logged for this sensor at each log interval with IDs of 4, 24 and 34 respectively. In HydroTel™ 2000 these will then relate to point identifiers of 4/0, 24/0 and 34/0.

### **2.5.4 Alarm Processing**

Each virtual sensor can be checked for two separate alarm conditions. Each alarm has separate trigger and reset levels, as well as an activation delay or accumulation period depending upon the data type. The alarms can also be used to control the digital output. See Sections 3.1.5 for further details on digital outputs.

### **2.5.5 Real Time Clock & Calendar**

The iRIS has a non-volatile real time clock that can be set by the user via a terminal session.

### **2.5.6 Security**

The iRIS can operate in Standard or Secure mode. In Standard mode, the totalisers can be reset via the touch pad or a terminal session. In Secure mode, the totalisers can only be reset via a terminal session.

The security mode is configured via a terminal session. See Option 7 in Section 4.3.1.

## 3 Installation

### 3.1 I/O Cable

All I/O and power supply terminations are via a screened multi-core cable. The function of each wire in the cable is shown in the diagram below.

Colour	Abbreviation	Description
Blue	AI1	Analogue Input #1
Brown	AI2	Analogue Input #2
Yellow	DI1	Digital Input #1
White	DI2	Digital Input #2
Purple	DO	Digital Output
Green	SGND	Signal Common Ground
Red	VIN+	5-15Vdc External Power Supply
Black	GND (-)	0Vdc External Power Supply / Ground

#### 3.1.1 Internal Lithium Battery

The iRIS has an internal AA size 3.6V lithium battery, which provides the power supply when no external dc power supply is available. When external power is connected, the internal battery is completely disconnected.

#### 3.1.2 External Power Supply

Although the iRIS is designed to operate solely from its internal battery for many months, you will typically need to connect an external supply to the unit so that the internal battery remains in a charged state. Any external dc power source ranging from 6 – 15 Vdc can be connected, including a solar panel, without requiring an additional solar regulator.

The external power supply is protected against reverse connection or over-voltage by ultra-fast acting protection devices and a self-resetting semiconductor fuse.

#### 3.1.3 Analogue Inputs

Analogue inputs are uni-polar 0-5Vdc with 12bit resolution. They present a load impedance of 100K $\Omega$ .

Scaling factors should be chosen to convert from a raw value of 0-5000, which reflects the input signal range of 0-5V (0-5000mV). When current sources are used, an external sink resistor (typically 250 $\Omega$ ) must be fitted between the analogue input and AGND.

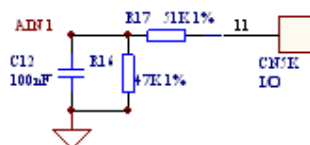

Analogue Input Circuit

### 3.1.4 Digital Inputs

The digital inputs are configured for electronic switching at up to 5kHz and it is necessary to pull the input down to 0Vdc to activate it. In this mode the input is normally pulled up to 3.6V through a 57K $\Omega$  resistance, providing a wetting current of approximately 60 $\mu$ A. Inputs will handle up to 30Vdc in the off state for parallel connection across existing equipment. .

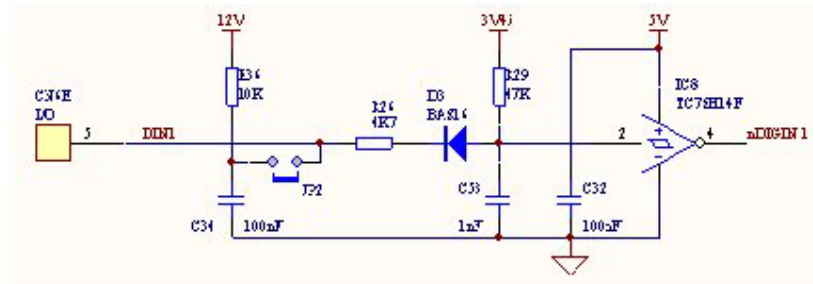

Digital Input Circuit

### 3.1.5 Digital Output

The Digital output is open drain pull-down and is capable of sinking up to 300mA at 30Vdc. Typically this could be used to drive a relay powered by an auxiliary d.c supply (e.g. 12V). In this mode, the negative of the relay supply must be connected to the iRIS GND wire (black).

**NOTE: For applications requiring a solid-state switched supply for controlling small loads such as pressure transducers, iQuest can supply a small transistor switch module that will invert the digital output. See Appendix A – Transistor Output Switch for more information.**

The output can be programmed to follow a schedule for use in powering external sensors/circuits, or operate in response to an alarm activation from any of the sensors.

See Section 4.3.6 for details on the digital output modes.

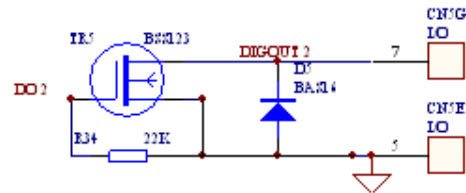

Digital Output Circuit

### 3.2 Mounting

The iRIS 120 is designed to operate as a free-standing unit, located within a sensor housing or telemetry cabinet. It does not, therefore feature any integrated mounting hardware. If desired, the unit can be fixed to a back plate or bracket by means of industrial quality double-sided tape or Velcro®.

## 4 Configuration

The iRIS configuration is initially achieved through the connection of a terminal to the internal serial port. Upon detection of a terminal connection via the DSR signal, the iRIS will output to the terminal screen a welcome message followed by the main menu. The following sections describe how to set up a terminal connection and the menu options available while connected.

This description assumes a computer running the Microsoft® Windows® operating system is being used and all examples relate to the standard Windows® terminal emulator application, HyperTerminal™.

### 4.1 Terminal Connection

The iRIS RS232 port is a DTE (Data Terminal Equipment) configured port and is identical in pinout and signal allocation to that of an IBM compatible PC's RS232 port. Therefore the cable required is the same as that for computer to computer communication.

To access the iRIS configuration terminal session, connect a full null-modem cable (as shown below) between a communication port (e.g. COM1) on your computer and the RS232 port of the iRIS. The null modem cable configuration has the three main signal pairs crossed over. These pairs are TXD/RXD, RTS/CTS and DTR/DSR.

	PC DB9F		iRIS DB9F	
1	CD	—————	CD	1
2	RXD	—————	TXD	3
3	TXD	—————	RXD	2
4	DTR	—————	DSR	6
5	SG	—————	SG	5
6	DSR	—————	DTR	4
7	RTS	—————	CTS	8
8	CTS	—————	RTS	7
9	RI	—————	RI	9

## 4.2 Terminal Cfg

Start Windows® HyperTerminal™ and create a new connection called “iRIS”. Set your terminal properties as shown in the dialog boxes below.

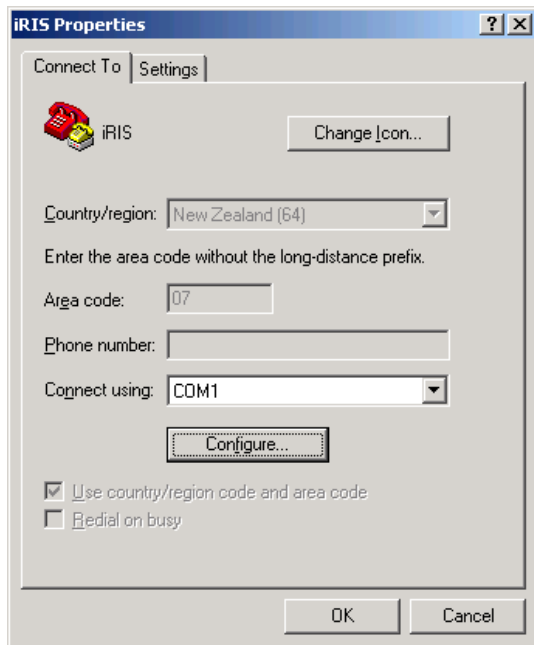

If you have connected the iRIS to any port other than COM1, make an appropriate selection from the drop down combo box.

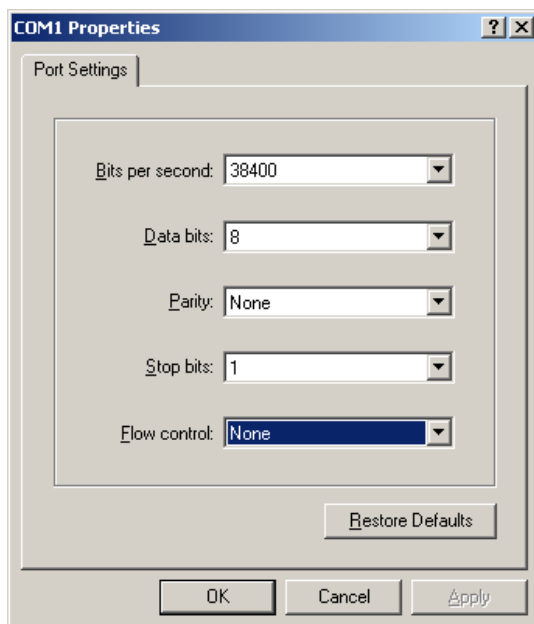

The iRIS RS232 serial port is set by default to a speed of 38400 bps. Flow control is not required.

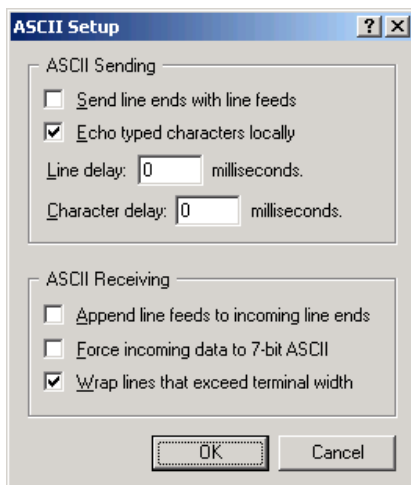
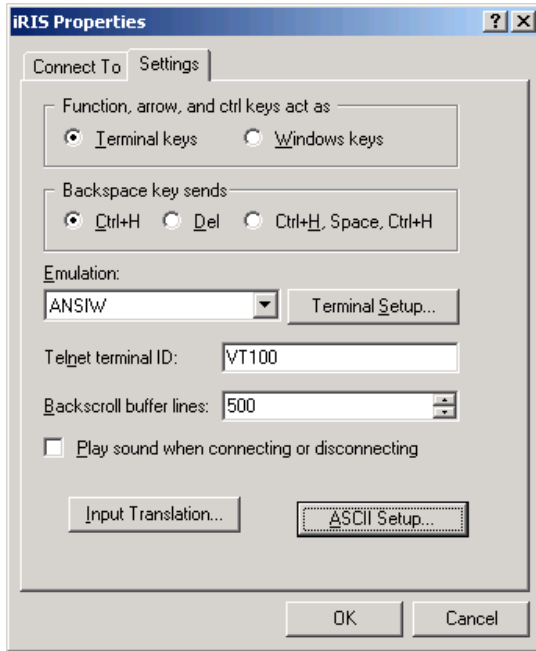

Because the iRIS does not echo received characters, it is necessary to enable “Echo typed characters locally” otherwise you will not see characters that you type in at the terminal.

## 4.3 Terminal Menus

When a terminal session has been established with the iRIS through the RS232 port you will be presented with a welcome message and the main menu will be displayed. To make a menu selection, type a number followed by <Enter>. Invalid menu selections will result in the display of an error message on the terminal. The current value of each settable item is enclosed in square braces (e.g. [1234]). To keep the current value for any setting, just press <Enter> when prompted for a new value.

The overall menu structure is shown graphically below:

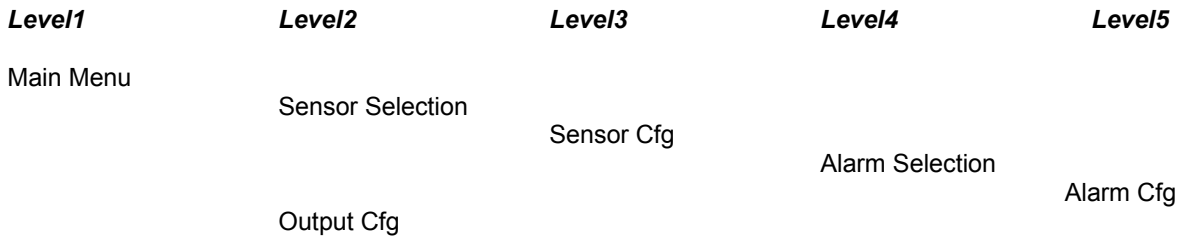

### 4.3.1 Main Menu (Level 1)

The first menu displayed is the Main Menu. From here, you can make the following choices:

```
* iRIS 120 (SN AG2-0001 / F1.00 / S1.00)
1 Site Name [iRIS 120 Demo]
2 Scan Mode [Timed: 15 mins]
3 Sensors
4 Output
5 Date [25 May 2005]
6 Time [11:14:19]
7 Security Mode [Secure]
8 Initialize
9 Shutdown
>
```

#### Option 1

Select this option to enter a name for the site that will be displayed on the main title screen of the LCD. Note that the maximum length of the site name is fixed at 19 characters, but the visible LCD width is 12 characters.

#### Option 2

Select this option to change the scan mode and rate for the unit. The scan rate represents the number of minutes that should elapse between successive scans when the mode is "Timed". See Section 3.1.5 for further information on scan modes and scan rates.

#### Option 3

Select this option to display the Sensor Cfg menu.

#### Option 4

Select this option to display the Digital Output Cfg menu.

#### Option 5

When this option is selected you will be prompted to enter the current local date as a string containing four digits for year, two digits for month and two digits for day. It is imperative that all 8 digits are entered.

```
> Date (YYYYMMDD) =
```

**Option 6**

When this option is selected you will be prompted to enter the current local time as a string containing two digits for hour, two digits for minute and two digits for second. It is imperative that all 6 digits are entered.

```
> Time (HHMMSS)=
```

**Option 7**

When this option is selected you will be prompted to enter a security mode. This is used to restrict access to specific LCD screens if required. If the mode is set to 'Standard' (factory default) then all LCD screens are accessible and totals can be reset using the touch pad. If the mode is set to 'Secure', it is not possible to reset the totals from the touch pad.

```
> Security Mode (0:Standard 1:Secure)=
```

**Option 8**

This option allows you to initialise the unit before deployment. This resets the totalisers and also the logging memory. This is useful to eliminate invalid samples that may have been logged prior to commissioning or if the unit has been reconfigured and deployed in a different location. Type 'init' (lower case, without the quotes) at the prompt to confirm this action.

```
> Type 'init' to initialize the unit  
=
```

The unit will acknowledge the request as shown and return to the main menu.

```
Unit has been initialized.  
Totals and pointers reset.
```

**Option 9**

Selecting this option allows you to put the unit into its dormant state for storage. This action is recommended to maximize the life of the internal lithium battery. Type 'shutdown' (lower case, without the quotes) at the prompt to confirm this action.

```
> Type 'shutdown' to turn the unit off  
=
```

The unit will acknowledge the request and remain connected for a few seconds before disconnecting and shutting down.

```
Unit has been shut down.  
Hardware reset required to restart.
```

For a detailed explanation of the dormant state, please refer to Section 5.3.

### 4.3.2 Sensor Selection (Level 2)

The Sensor Configuration menu is where you select the sensor that you want to configure. From this menu, you can see at a glance which sensors are enabled for logging and if enabled, their source and name.

```
* Sensor Cfg
0 Exit
1 Sen1 [Dis]
2 Sen2 [Dis]
3 Sen3 [Dis]
4 Sen4 [Dis]
>
```

#### Option 0

Select this option to return to the main menu.

#### Option 1

Select this option to display the set-up menu for Sensor 1.

#### Option 2

Select this option to display the set-up menu for Sensor 2.

#### Option 3

Select this option to display the set-up menu for Sensor 3.

#### Option 4

Select this option to display the set-up menu for Sensor 4.

### 4.3.3 Sensor Cfg (Level 3)

The Sensor Cfg menu is used to configure each of the four main virtual sensors. Refer to the datalogging features (Section 0) of this manual for a discussion on virtual sensors. This menu also shows the current scaled measurement value for this sensor

```
* Sensor 1 Cfg
(Now: 1.9620)
0 Exit
1 Source [1: Analog 1]
2 Name [Water Lvl]
3 Mode [Instant]
4 Multiplier [ 0.001]
5 Offset [ 0.0000]
6 Log Multiplier [1000]
7 Log Rate [15min]
8 Alarms
9 Data
>
```

#### Option 0

Select this option to return to the main Sensor Cfg menu.

**Option 1**

When this option is selected you will be prompted to enter a number representing the source from which the virtual sensor should acquire its data. Use zero to disable the sensor. Valid data sources are shown in the table below.

> Source (0..10)=

Source	Description	Raw Range	Multiplier	Offset	Log Multiplier
0	Unused / disabled	N/A	N/A	N/A	N/A
1	Analogue Input 1	0 to 5000			
2	Analogue Input 2	0 to 5000			
3	Pulse Counter on Digital Input 1	0 to 1			
4	Pulse Counter on Digital Input 2	0 to 1			
5	Auto Pulse Counter on Digital Input 1	0 to 1			
6	Auto Pulse Counter on Digital Input 2	0 to 1			
7	Frequency Counter on Digital In 1	0 to 5000Hz			
8	Frequency Counter on Digital In 2	0 to 5000Hz			
9	Up/Down Counter on Digital Ins 1 & 2	-32768 to 32767			
10	Database Location	-32768 to 32767			

**Option 2**

When this option is selected you will be prompted to enter a name for the sensor (maximum 10 characters). This name will be displayed on the iRIS LCD sensor screens.

> Name (max 10)=

**Option 3**

When this option is selected you will be prompted to enter a number representing the processing mode.

> Mode (0..3)=

Valid modes are:

Mode	Name	Description
0	Instant	Logs only the most recent sample
1	Full Period Average	Logs the average of all samples taken over logging period
2	Event	(Only valid for pulse input sources) Logs non-zero samples. If the logging rate is 0, then any pulse is logged immediately. If the logging rate is > 0, then the total accumulated in the period is logged only if it is not zero. In this mode, if there was no sample logged at the last log time, a zero sample is also logged, time stamped with last log time/date. This is required for time series management purposes.
3	Vector Average (for Wind Direction)	Logs the average of all samples taken over logging period, but uses vector calculations to calculate the average.

After selecting the mode, you will then be prompted to configure the extended datalogging options by entering in a number that represents a set of option "flags".

> Flags (+1:Min +2:Max +4:Dev +8:Flow)=

**The number entered is the sum of the extended logging options you want to enable.** See the table below for a listing of all the valid options.

Flag Value 1 = Log Minimum Value sampled in log period

Flag Value 2 = Log Maximum Value sampled in log period

Flag Value 4 = Log Standard Deviation of samples in log period

Flag Value 8 = Log calculated Flow Rate over log period (only for sensors with pulse source 3 or 4)

Flag Value	Description
0	No additional logging
1	Log Minimum
2	Log Maximum
3	Log Minimum and Maximum
4	Log Standard Deviation
5	Log Minimum and Standard Deviation
6	Log Maximum and Standard Deviation
7	Log Minimum, Maximum and Standard Deviation
8	Log Flow Rate
9	Log Minimum and Flow Rate
10	Log Maximum and Flow Rate
11	Log Minimum, Maximum and Flow Rate
12	Log Standard Deviation and Flow Rate
13	Log Minimum, Standard Deviation and Flow Rate
14	Log Maximum, Standard Deviation and Flow Rate
15	Log Minimum, Maximum, Standard Deviation and Flow Rate

**Option 4**

When this option is selected you will be prompted to enter a scaling multiplier. This multiplier is used to convert the raw input into engineering units.

> Multiplier=

**Option 5**

When this option is selected you will be prompted to enter a scaling offset. This offset is added to the scaled engineering value.

> Offset=

**Option 6**

When this option is selected you will be prompted to enter a logging multiplier to convert from engineering units to an integer value to storage in the logging memory.

> Log Multiplier=

For example, if you need to log a measurement that is accurate to two decimal places you will need to enter a logging multiplier of 100.

**NOTE: Care needs to be taken in the selection of an appropriate logging multiplier because the iRIS logs data as signed 16-bit integer values (-32768 to 32767). This means that the maximum scaled value multiplied by the logging multiplier must not exceed 32767.**

**Option 7**

When this option is selected you will be prompted to enter a logging rate (in minutes) for the sensor.

> Log Rate=

If you wish to log digital data on change of state you can enter a value of 0. If this parameter is left at 0 for analogue sources, they will not be logged.

**Option 8**

Select this option to display the Alarm Configuration menu for the sensor.

**Option 9**

Select this information to view the logged data for the sensor. You will be prompted to enter the number of samples you would like returned

### 4.3.4 Alarm Selection (Level 4)

Use the Alarm Selection menu to decide which alarm you want to configure. You can see at a glance from this menu which alarms are enabled.

```
* Alarm Selection
0 Exit
1 Alarm #1 (Enabled)
2 Alarm #2 (Disabled)
>
```

#### Option 0

Select this option to return to the Sensor Cfg menu.

#### Option 1

Select this option to view the set-up menu for Alarm 1.

#### Option 2

Select this option to view the set-up menu for Alarm 2.

### 4.3.5 Alarm Cfg (Level 5)

The alarm set-up menu is the place to configure each sensor alarm.

```
* Alarm 1 Cfg
0 Exit
1 Enable [No]
2 Trigger [ 0.00]
3 Reset [ 0.00]
4 Duration [0min]
>
```

#### Option 0

Select this option to return to the Alarm Selection menu.

#### Option 1

When this option is selected you will be prompted to enable/disable the alarm.

```
> Enable (0:No 1:Yes)=
```

Enter a value of 0 to disable the alarm. Enter a value of 1 to enable it.

#### Option 2

When this option is selected you will be prompted to enter a trigger level for the alarm.

```
> Trigger=
```

Enter a value in engineering units that you want to use as the trigger point for the alarm. When the scaled value exceeds this limit the alarm will become active.

#### Option 3

When this option is selected you will be prompted to enter a reset level for the alarm.

```
> Reset=
```

Enter a value in engineering units that you want to use as the reset point for the alarm. When the scaled value falls below this limit the alarm will be deactivated. If the reset level is set to a value greater than the trigger level then the alarm is reverse acting. This mode is normally used for low voltage alarms.

**Option 4**

When this option is selected you will be prompted to enter a time in seconds to delay alarm activation. This can be used to implement hysteresis for analogue data sources. If the data source is one of the internal counters then this time is used to totalise individual sample values. If the total over the given alarm duration is above the trigger level then an alarm is generated. Typically this feature is used for rainfall alarms.

> Duration (min)=

**4.3.6 Output Cfg (Level 2)**

The Output Cfg menu is used to configure the digital output.

```
* Digital Output Cfg
0 Exit
1 Enable [Yes]
2 Polarity [Normal]
3 Mode [Schedule]
4 Duration [30sec]
5 Frequency [1min]
6 Start Time [0000]
7 End Time [2359]
>
```

**Option 0**

Select this option to return to the Output Selection menu.

**Option 1**

When this option is selected you will be prompted to enable/disable the output.

> Enable (0:No 1:Yes)=

Enter a value of 0 if you want to disable the output. Enter a value of 1 if you want to enable it.

**Option 2**

When this option is selected you will be prompted to select the switching polarity of the output. This relates to the output's electrical state with respect to its logical on/off state.

If the polarity setting is 0 (normal), the output will actively pull down to 0V when the output logical state is on and be high impedance (open-circuit) when the output is logically off.

If the polarity setting is 1 (inverted), the output will be high impedance (open-circuit) when the output logical state is on and be actively pulled down to 0V when the output is logically off.

> Polarity (0:Normal 1:Inverted)=

**Option 3**

When this option is selected you will be prompted to enter a number representing the operating mode of the output.

> Mode (0..1)=

Valid modes are:

Source	Description
0	Schedule. Follows the schedule as defined by the settings in alarm config options 4-7.
1	Alarm. If any alarm is active, the digital output will be on.

#### Option 4

When this option is selected you will be prompted to enter the length of time in seconds that you want the iRIS to keep the output energised if the mode is set to 0 (schedule).

```
> Duration (sec)=
```

#### Option 5

When this option is selected you will be prompted to enter the length of time in minutes between the successive operations of the output if the mode is set to 0 (schedule).

```
> Frequency (min)=
```

#### Option 6

When this option is selected you will be prompted to enter a string representing the time at which the iRIS is allowed to start controlling the output if the mode is set to 0 (schedule).

```
> Start Time (HHNN)=
```

#### Option 7

When this option is selected you will be prompted to enter a string representing the time at which the iRIS must stop controlling the output if the mode is set to 0 (schedule).

```
> End Time (HHNN)=
```

### Typical Scheduled Output Example

A ground water site using an iRIS is required to log a sample every hour that is obtained from a pressure transducer whose power supply is controlled from the digital output via a transistor switch. The transducer needs to be powered up for one minute prior to the measurement being taken and logged. The settings required to achieve this are shown below.

```
* Digital Output Cfg
0 Exit
1 Enable [Yes]
2 Polarity [Normal]
3 Mode [Schedule]
4 Duration [65 sec]
5 Frequency [60 min]
6 Start Time [0059]
7 End Time [2359]
```

The output will be activated at the beginning of the 59<sup>th</sup> minute of each hour in the day, starting at 00:59. It will remain on for 65 seconds, ensuring that the sensor is still powered up at the point when the reading is captured on the hour. The final output activation for the day will occur at 23:59 in preparation for the midnight measurement.

## 5 Operation

### 5.1 LCD & Keypad

#### 5.1.1 LCD Operation

The iRIS LCD is controlled to optimise power consumption. If the display has powered down, the unit is in a lower power mode and can be woken by pressing any key on the keypad. If the unit still fails to respond, the unit may be in its dormant state, in which case a reset will be required to reactivate the unit. See Section 5.3 for further details.

After 15 seconds have elapsed with no key presses, the display will power down again, although other functions continue normally.

#### 5.1.2 Status Icons

At the top of the LCD is a row of status icons.

<p><u>Padlock</u></p> <p>Indicates the current operating mode</p> <ul style="list-style-type: none"> <li>➤ <i>Invisible</i>      Standard mode</li> <li>➤ <i>Solid</i>            Secure mode – totals cannot be reset via the touch pad</li> </ul>
<p><u>Battery</u></p> <p>Indicates which is the current power source</p> <ul style="list-style-type: none"> <li>➤ <i>Invisible</i>      Unit operating on external power</li> <li>➤ <i>Solid</i>            Unit operating on internal battery</li> </ul>
<p><u>Spanner</u></p> <p>Indicates active RS232 terminal connection</p> <ul style="list-style-type: none"> <li>➤ <i>Invisible</i>      No terminal connected</li> <li>➤ <i>Solid</i>            Terminal connected</li> </ul>

#### 5.1.3 Touch Pad

The touch pad is used to navigate through the LCD screens. It is also used to reset the totalisers (not available if the unit is operating in Secure mode).

#### 5.1.4 Display Menu Structure

Scroll through the screens by pressing and releasing the touch pad. The display loops back to the beginning when the touch pad is pressed on the last screen. The screens appear in the order in which they are presented here.

#### 5.1.4.1 Title

The first screen to be displayed is the Title screen. This basic screen shows the unit name, serial number as well as the current time and date.

```
iRIS120 Demo
S/N:AG2-0001
  08:37:46
16 May 2005
```

#### 5.1.4.2 System Status

The System Status screen shows the firmware (F) and software (V) version numbers, the unit's mode and scan time (if mode is timed) and finally, the current end of data (EOD) pointer value. The EOD pointer value can range from 0 to 249999. It will always be zero immediately following unit initialization.

```
F1.00/V1.00

Mode: Batt
Temp: 21.6°C
```

#### 5.1.4.3 I/O Summary

The I/O Summary screen shows the immediate state of the digital and analogue I/O (inputs/out). The information shown is the voltage being measured at the AI1 and AI2 terminals (in mV) as well as the current status of the digital inputs and output (0=OFF, 1=ON). This screen is useful for confirming the electrical connections to the unit when installing or checking it.

```
AI1: 1754 mV
AI2:  682 mV
DI1:0  DI2:1
DO1:
```

#### 5.1.4.4 Sensor Status

The sensors that are enabled are presented in order, one screen at a time. The screen is the same for each sensor and provides an overview of the sensor's status. Disabled sensors are not shown.

Line 1 indicates sensor ID, data source and its composite status including:

- '.' if sensor is enabled
- ':' if sensor and alarm(s) are enabled
- '\*' if sensor and alarm(s) are enabled and alarm(s) currently active

Line 2 indicates the raw input value.

Line 3 indicates the scaled (engineering unit's) value.

Line 4 indicates the last logged value.

```
2: Flow Rate
→   1906
←   11.07
↓   1262
```

#### 5.1.4.5 Total Screen (DI1)

The first Total screen shows the running totals for digital input, DI1. The values presented represent yesterday's total, the total so far today and the total running total since the totalisers were last reset.

TOTAL	(DI1)
Yst	55.6
Day	17.8
Run	5432.4

#### 5.1.4.6 Total Screen (DI2)

The second Total screen shows the running totals for digital input DI2. The values presented represent yesterday's total, the total so far today and the total running total since the totalisers were last reset.

TOTAL	(DI2)
Yst	134.7
Day	26.4
Run	11276.3

#### 5.1.4.7 Reset Totals Screen

The Total Reset screen is used to reset the daily and running totals for both inputs. Press the touch pad once to scroll back to the main screen. Press and hold the touch pad for 3 seconds to reset the daily and running totals for both DI1 and DI2. A message indicating that the reset has occurred will be displayed.

RESET TOTALS
Hold for 3
seconds to
reset

**NOTE:** *The two pulse counters' totalisers operate continually, irrespective of whether or not they are configured as a source for any of the sensors.*

## 5.2 General Hints

- If the iRIS will not to be used for some time, put it into its dormant state to help extend the life of the internal battery.
- Always check the time and date when commissioning the unit.
- Initializing the unit prior to deployment is recommended to avoid unwanted and/or invalid samples being logged. See Option 8 in Section 4.3.1

## 5.3 Dormant State

The iRIS logger is shipped in its dormant state. In this condition, the entire circuit is stopped; no sampling occurs, no logging occurs, the touch pad and LCD are disabled and the real-time clock is halted. This is a maximum power saving state and is designed to preserve the internal battery life if the unit is likely to be stored or decommissioned for an extended period of time.

In order to wake the logger from the dormant state, it is necessary to carry out a hardware reset. This is achieved by briefly shorting pin 9 of the RS-232 connector to the connector case. This can be done with a small flat-bladed screwdriver or a piece of wire. The two pins are shown in the diagram below.

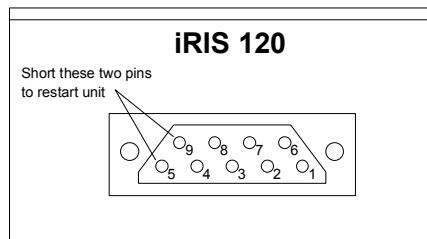

When the iRIS wakes from its dormant state, the LCD display will power up and the touch pad will be reactivated. It is important to remember to check and if necessary set the internal date and time before commissioning the logger.

To put the iRIS back into its dormant state, enter the appropriate command via a terminal session. For details refer to Option 9 in Section 4.3.1.

## 6 Sensor Connection Examples

### 6.1 Connecting a Flow Meter or Rain Gauge

One of the most common uses for the iRIS is logging data from pulse sources such as flow meters or rain gauges.

Connecting such devices to the iRIS is very simple – wire the switch between the appropriate digital input (DI1 or DI2) and the digital ground (DGND) terminal. Both of the digital inputs provide a “wetting current” for clean contact sources, but transistor switches and active signals (ones that supply a voltage) can also be used. If a transistor switch is used, connect the collector (+) to the digital input and the emitter (-) to the DGND. See Section 3.1.4 for details on the digital inputs and setting up the input for debounce.

Both inputs can be used simultaneously and each input has three associated totalisers, which are viewable from the LCD. See Section 5.1.4.5. These totalisers operate even if the input is not configured as a source to one of the six virtual sensors.

The diagram below shows the typical connection diagram for such an installation. It assumes the use of DI1 as the pulse input channel. The external power source can be any d.c supply from 5V – 15V.

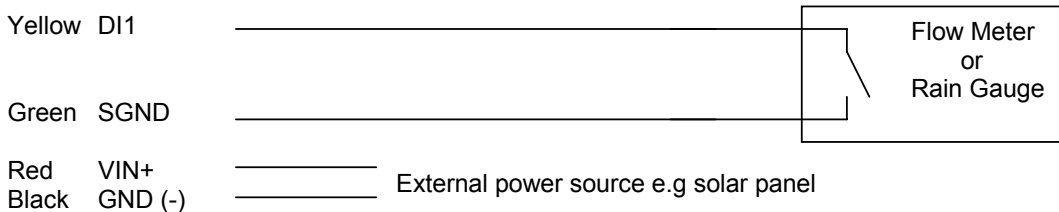

The sensor should be configured for the correct channel, scaling and logging regime as described in Section 4.3.3. Event mode (Sensor Mode=2) can be used to reduce the quantity of data logged, especially for rainfall where the actual data density is low.

## 6.2 Connecting a 0-5V Pressure Transducer

Connecting a standard sensor (such as a pressure transducer that provides a 0-5V signal) to an iRIS is relatively straightforward. An external 12V battery (7A/Hr or larger) is required to power the sensor but this can optionally be controlled by the iRIS' digital output to save power.

The diagram below shows the typical connection diagram for such an installation. It assumes the use of AI1 as the desired input channel. It also shows the connection of a transistor switch module with control from DO1.

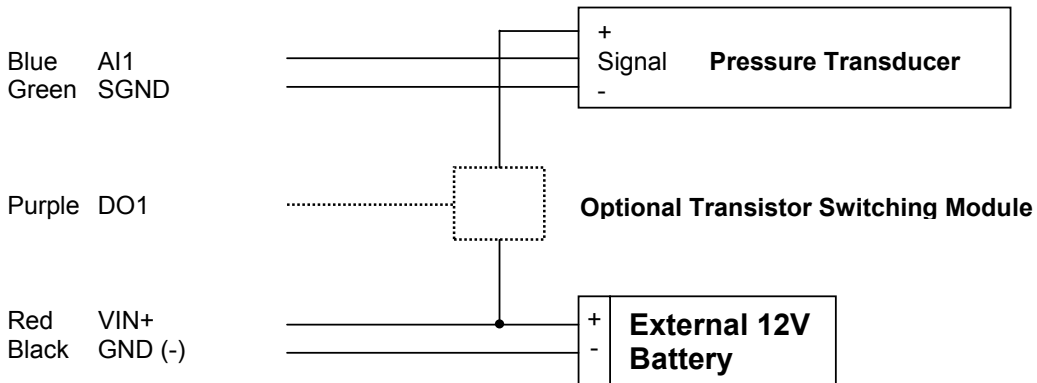

The sensor should be configured for the correct channel, scaling and logging regime as described in Section 4.3.3.

**NOTE:** The iRIS supports activation of the digital output with a schedule. See Section for more details and an example. Therefore, if further power reduction is to be achieved by controlling the transducer power, follow this procedure:

1. **Install a transistor switch module in series with the transducer power lead and control it from the digital output. See Appendix A for details on the transistor switch module.**
2. **Configure the digital output's mode to be Schedule (Mode = 0).**
3. **Set up the digital output's schedule to match the sensor's logging period, but with the digital output being set to activate the desired amount of time before the sensor is to log and with sufficient "on" time to ensure an overlap with the logging time.**
4. **Ensure the sensor mode is set to 0 (Instant).**

### 6.3 Connecting a 2-Wire Loop-Powered 4-20mA Sensor

The iRIS also supports the connection of many types of industry standard 4-20mA current loop instruments such as ultrasonic or radar level sensors. A very common configuration used with these devices is known as two-wire or loop-powered mode. This requires only two wires to the sensor and the 4-20mA loop current provides power for the sensor as well as being the proportional analogue sensor signal.

These sensors often require a minimum voltage across them that may not be reliably achieved with a 12V supply, taking into account the voltage drop across the sense resistor. In such cases, a separate 12-24V boosted sensor supply is recommended.

The diagram below shows the recommended connection diagram for such an installation. It assumes the use of AI1 as the desired input channel.

The 250Ω sense resistor generates a 1-5V signal (from the 4-20mA current), which is then measured at the analogue input. The sensor should be configured for the correct channel, scaling and logging regime as described in Section 4.3.3. An offset value will be required as part of the configuration, as the 4mA (1V) offset needs to be eliminated.

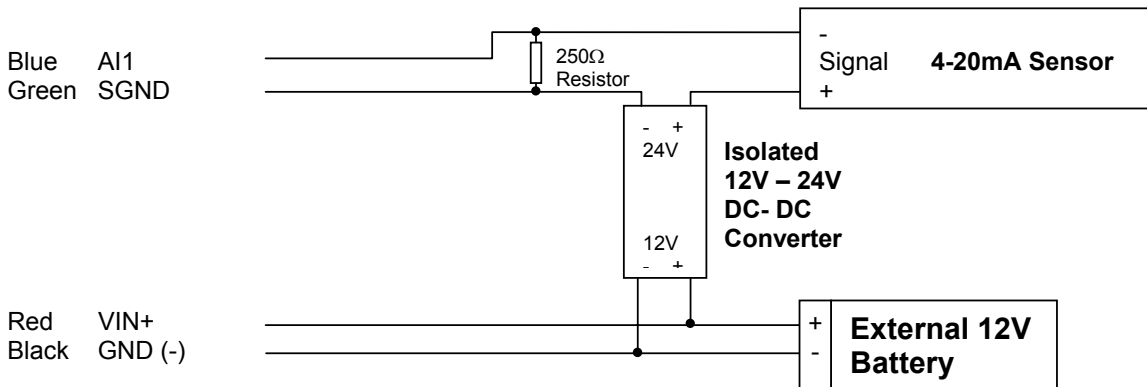

## 6.4 Connecting an Up/Down Water Level Instrument

A relatively common type of digital water level instrument is one that provides two pulse outputs. One output generates a pulse for each increment and the other for each decrement in level. The iRIS maintains a record of these steps and therefore the relative level.

These instruments normally require a 12V supply, which can also be used to provide external power to the iRIS.

The diagram below shows the required connects for such an installation. The incrementing output must be connected to DI1 and the decrementing output to DI2.

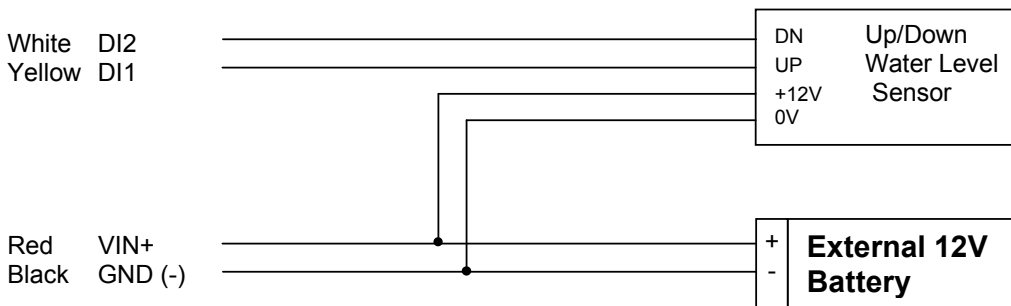

## 7 Troubleshooting

This section offers possible answers to common installation and/or configuration issues.

### ***7.1 The LCD display is blank***

If the unit is operating under external power, the LCD is permanently on. If the unit is operating under the power of its internal battery, the LCD is automatically turned off if the touch pad has not been depressed for 15 seconds. Simply tap the touch pad to 'wake-up' the display.

If the LCD still fails to display, the logger may be in its battery saving dormant state. This state can be entered via a terminal session, and the logger will no longer log any values, respond to the touch pad or power up the LCD. It is designed as a power-saving mechanism if the unit is likely to be stored out of service for an extended period of time. To wake-up the logger from its dormant state, a hardware reset is required. For details on the dormant state and hardware resets, refer to Section 5.3.

If the internal battery has been exhausted, the unit will require an external power source before it can be used. In this event, please refer to Section 3.1.2 for details on suitable power supplies and connections.

### ***7.2 The menu option for resetting totals is not available***

The menu option for resetting totals is not displayed if the unit is in secure mode. The mode can be changed via a terminal session. The totals can be reset via a terminal session even if the logger is in secure mode.

## 8 User Notes

## 9 Appendix A – Transistor Output Switch

The iRIS digital output operates in an open-drain, pull-down mode. This configuration is normally used to control an external relay or similar device and it offers the advantage of allowing a wide range of relay supply voltages (up to 30V), which do not necessarily have to relate to the supply voltage of the iRIS itself.

However, another common use for a digital output is to control a sensor such as a pressure transducer. In this case, minimising power consumption is the main aim of the control. The optional transistor switching module inverts the digital output and provides a switched power supply for the transducer or other device. Being solid state, the extra current that a relay coil would draw is eliminated.

The switch module is a small unit that with three wires, one of which has a screw terminal to attach the transducer supply wire. The wires and their functions are as follows:

**RED: Supply Voltage In**

Connect this to the positive lead of a suitable dc power supply and also connect that power supply's negative lead to the GND terminal of the iRIS.

**PURPLE: Switched Output**

Connect the transducer (or other load) supply wire to this wire.

**GREY: Control**

Connect this wire to the appropriate digital output. Normally DO1.

The module has a small red LED that will be illuminated when the digital output is activated.

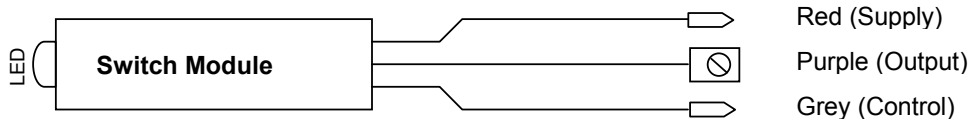

**Transistor Switch Module Overview**

### Switching Module Specification

Maximum Supply Voltage:	30V
Maximum Switching Current:	300mA
Lead Length:	100mm