



iRIS-CAM

User Guide



Issue 1

Revision History		
Issue 1	24/11/06	Initial version

Disclaimer

Under no circumstances will iQuest (NZ) Ltd be liable or responsible for any consequential damage or loss that may arise from the use of this product.

All examples and diagrams shown in this manual and any supplied software examples are intended as a guide to understanding this product, not to guarantee operation. iQuest (NZ) Ltd accepts no responsibility for use of this product based on this information or these examples.

Owing to the wide variety of possible applications of this product, you must satisfy yourself as to its suitability to your specific application.

© 2006, iQuest (NZ) Ltd
All rights reserved.

This publication, or any part of it, and any software accompanying it may not be copied, photocopied, reproduced, translated or communicated to any third party, or reduced to electronic medium without prior written permission from iQuest (NZ) Ltd.

Contents

1 Introduction	2
1.1 About this Manual	2
1.2 Hardware Required	2
1.3 Support.....	2
2 Overview	3
2.1 Introduction	3
2.2 Specifications	3
3 Installation	4
3.1 Mounting	4
3.2 Connecting the iRIS-CAM to iRIS	5
4.1 PC Based Commissioning Software	5
4.1.1 Installing PC Based Software & USB Drivers	5
4.2 Connecting to PC	6
4.3 Focusing.....	6
5 Configuration	7
5.1 iRIS 320 Configuration.....	7
5.1.1 Installing iRIS based Software	7
5.1.2 Configure the Camera on the IRIS320.....	8

1 Introduction

1.1 About this Manual

This manual is intended as a general guide for iRIS-CAM installation, commissioning and configuration. This manual is also available online in Adobe Acrobat® PDF format for registered users at www.iquest.co.nz

1.2 Hardware Required

- 1 x iRIS320, with free gland
- 1 x iRIS-CAM Kit, which contains:
 - 1 x iRIS Camera
 - 1 x iRIS 320 to iRIS-CAM adaptor board
 - 4 x Mounting bolts or screws
- 1 x iRIS-CAM Commissioning Kit (can be re-used), which contains:
 - 1 x USB adaptor
 - 1 x USB cable
 - 1 x Software and documentation CD

1.3 Support

Technical support for the iRIS-CAM is available by contacting:

iQuest (NZ) Ltd
P.O Box 15169
Hamilton
NEW ZEALAND

Tel: +64 7 857-0810
Fax: +64 7 857-0811
Email: support@iquest.co.nz

For latest information and software updates, visit the iQuest (NZ) Ltd web site at www.iquest.co.nz

2 Overview

2.1 Introduction

The iRIS-CAM is a camera accessory for the iRIS 320 data logger. It is supplied in an environmentally sealed (IP65) enclosure constructed from a special corrosion-resistant aluminium alloy that is finished in a hard-anodised coating. This provides a very high degree of mechanical strength and EMI shielding, and enables completely stand-alone mounting in outdoor situations. The enclosure is filled with epoxy resin and the lens is silicon greased in place, which means the potential for water ingress is extremely low.

When connect to an appropriately configured iRIS320 data logger, images can be taken, stored and then unloaded (at regular intervals) via any of the communication channels available to the iRIS (e.g. GPRS, CDMA, RS232, CSD).

2.2 Specifications

SIZE:	162mm x 116mm x 65mm (4.60in x 6.37in x 2.64in) (WxHxD)
CONNECTORS:	6 way rectangle connector on the end or 5m of shielded PVC cable
MASS:	300 g (10.6oz)
POWER SUPPLY:	3.3V d.c +/- 10% (powered via cable from iRIS)
RESOLUTION:	Selectable 80x60, 160x128, 320x240 or 640x480 pixels JPEG format, 24 bit colour
LENS:	F2.8 Focal length 4mm Integral IR filter
ENVIRONMENTAL:	Operating: -10 °C to +70 °C (14 °F to +158 °F) Storage: -10 °C to +85 °C (14 °F to +185 °F) Enclosure sealed to IP67

3 Installation

3.1 Mounting

This can be achieved with the use of the four M6 Allen Key® bolts or other suitable hardware such as wood screws. The diagram below shows the overall dimensions and position of the mounting holes for the IRIS-CAM. The correct orientation is shown in the diagram, where the engraved writing is the right way up. The cable extends from the left side of the enclosure when viewing the camera from the front.

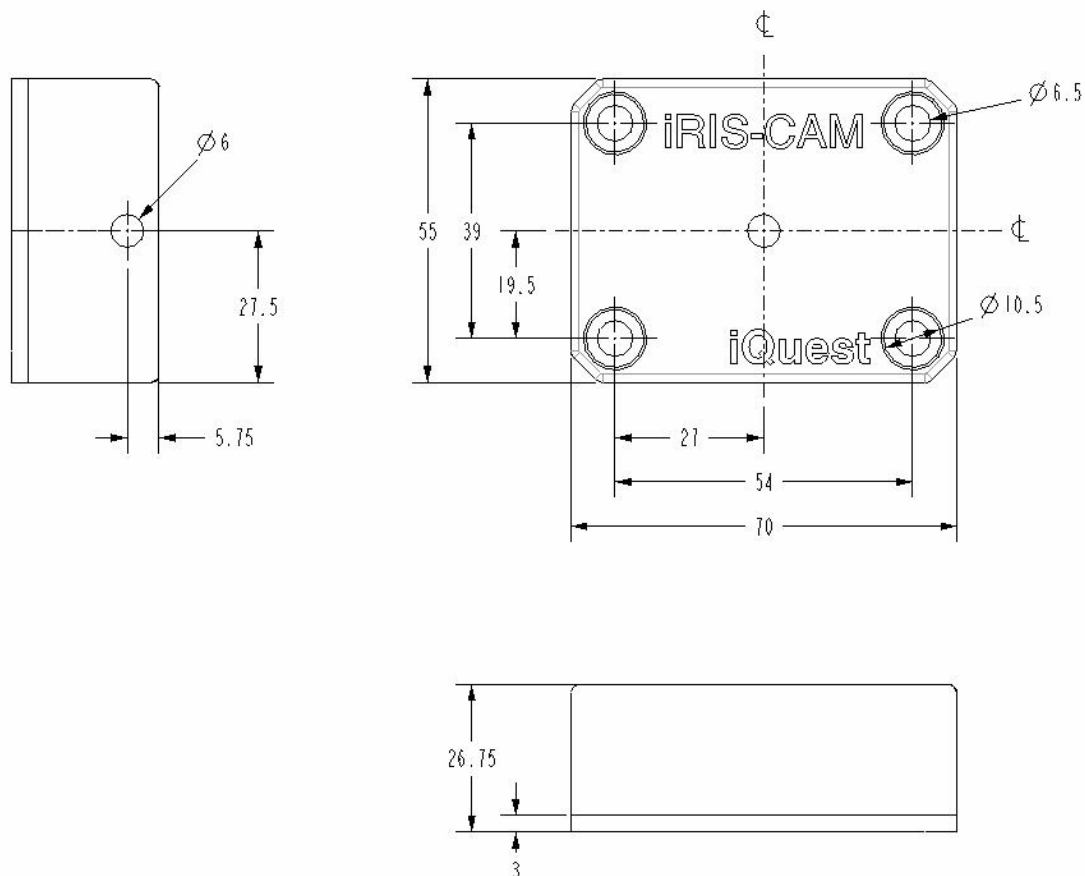

Due to the lens's small aperture it can be susceptible to image quality degradation due to droplet of water (creates a second lens). To minimize the effects, provide the camera lens with a rain shield; position the camera so that it points down and away from prevailing weather.

3.2 Connecting the iRIS-CAM to iRIS

Connecting the camera to the datalogger is a simple process. First disconnect all power to the logger then feed the camera cable through the gland. Next connect the iRIS-CAM 6 way connector to the adaptor board and then the adaptor board into 10 way connector at the top of the iRIS320 PCB. Finally tighten gland and re-power the logger.

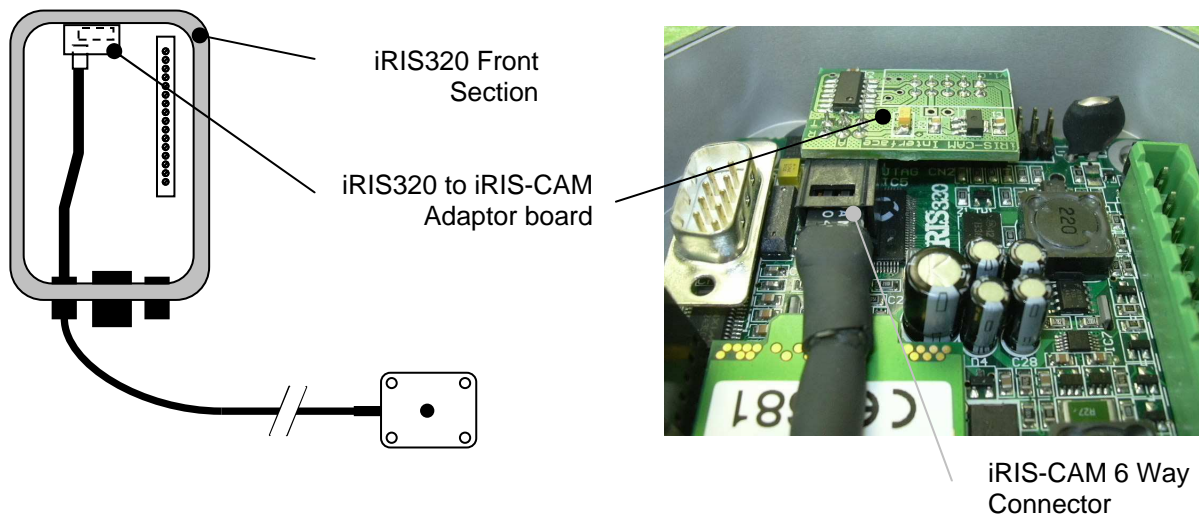

4 Commissioning

The easiest way to commission the iRIS-CAM is to connect it to the USB port of a laptop or desktop PC. This allows quick and repetitive collection of images from the camera, enabling quick focusing and alignment of the camera.

Note: It is important to install the Windows® iRIS-CAM USB adapter drivers before connecting the camera to the PC.

4.1 PC Based Commissioning Software

4.1.1 Installing PC Based Software & USB Drivers

The following list of steps will install the iRISCamera commissioning software and the Windows USB drivers for the iRIS-CAM adaptor.

1. Obtain the installation package from iQuest.¹
2. For the CD distribution:
 - a. Insert CD into PC's CDROM drive, if the installer does not auto start, run d:\iRISCAMInstaller.exe (where d:\ is the CDROM drive letter).
 - b. Click on **Install iRIS-CAM** button and follow the prompts.
3. For a Web Download:
 - a. Download the iRIS-CAM windows software installer package from www.iquest.co.nz
 - b. Run the iRISCAMInstaller.exe program and follow the instructions.
4. Once installation of the iRISCamera Software is complete and the installation program has been closed, install the USB drivers by:
 - a. Run the installer from Start->All Programs->iRIS-CAM->USB Driver Installer.
 - b. Click **Install** button. **Note:** if prompted with the message saying the software has not passed Windows Logo Verification, please ignore and click the **Continue Anyway** button.

¹ Software can be obtained from CD or the iQuest website: www.iquest.co.nz

4.2 Connecting to PC

Follow the simple list of steps to connect the iRIS-CAM to a Laptop and download images.

1. Connect the iRIS-CAM's 6 way connector to the USB adaptor (disconnect from iRIS320 if required).
2. Connect the USB Cable to the USB adaptor and then connect the other end to a USB port on the PC. **Note: It is important to install the Windows® iRIS-CAM USB adaptor drivers before connecting the camera to the PC see section 4.1.1.**

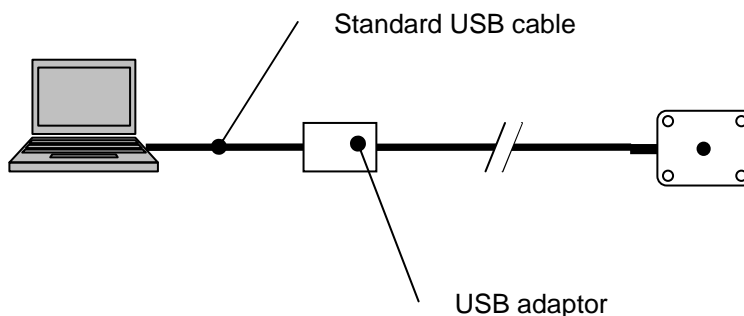
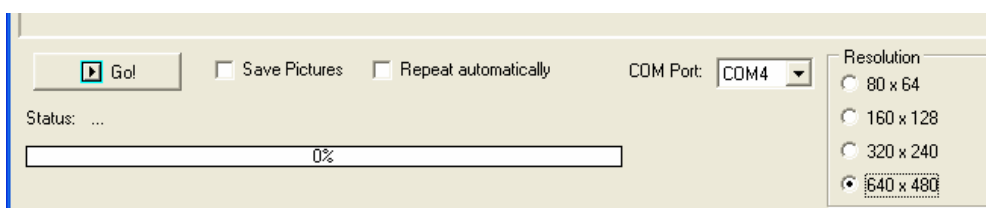

Figure 1 Show how to connect iRIS-CAM to a PC.

3. When the cables are connected for the first time a popup box will appear on the PC indicating an iRIS Camera Adaptor has been found and a second box will appear named **Found New Hardware Wizard**.
 - a. When prompted whether to search online for drivers choose **No, not this time** option and press the **Next** button twice. **Note:** if prompted with the message saying the software has not passed Windows Logo Verification, please ignore and click the **Continue Anyway** button.
 - b. Click the **Finish** button.
 - c. Repeat steps 3&4 for the iRIS Camera Virtual Port.
4. Start the iRIS-CAM Commissioning Software (Start->All Programs->iRIS-CAM->iRIS-CAM). This will bring up a box should popup indicating the USB adaptor has been found. Click **Ok** button to proceed.
5. Select the resolution and the repeat function as desired.



6. Click the Go button to start downloading images. Note: to stop automatic repeat feature, uncheck the Repeat Automatically checkbox.

4.3 Focusing

Focusing of the camera can be achieved by screwing the lens clockwise or anticlockwise when viewing the camera from the front. The camera is factory set to for midrange focus.

- Anticlockwise rotation (or screw out) focuses on near objects
- Clockwise rotation (or screw in) focuses on distant objects

5 Configuration

5.1 iRIS 320 Configuration

Once the camera has been installed and commissioned using the PC interface the iRIS320 needs to be programmed and configured.

5.1.1 Installing iRIS based Software

Installation of iRIS datalogger based software is achieved by using the iLink software package on a PC connected to the logger via a null modem cable².

1. Check the Firmware version is VN2.21 or higher, if it is, move onto step 2. If not follow these steps:
 - a. Obtain the latest version, **iRIS320_XXX_YY.fls** from iQuest, where XXX is the version number (XXX=221 or higher), and YY is the PCB revision (YY=11 or 12).
 - b. Start iLink and connect to the logger³.
 - c. Select Tools->Advanced->Flash Executive menu option.
 - d. Click the top **Browse** button and locate the file obtained in step a.
 - e. Click **Download** button.
 - f. When the download is complete, click **OK** button.
 - g. Click **Start Flash Upgrade** button.
2. Obtain the three iRIS 320 program files.
For a GPRS based iRIS:

iRIS_GPRS_ZZZ_1.irs
iRIS_GPRS_Camera_ZZZ_2.irs
iRIS_GPRS_ZZZ_3.irs

For a CDMA based iRIS:

iRIS_CDMA_ZZZ_1.irs
iRIS_CDMA_Camera_ZZZ_2.irs
iRIS_CDMA_ZZZ_3.irs

Note: Where the ZZZ is the software version number.

3. Start iLink and connect to the logger³.
4. Click the **Program** toolbar button (or Tools->Program menu option).
5. Click **Stop Programs** button.
6. If the existing logger data and configuration are no longer required click the **Clear Device Button**. Otherwise proceed to the next step.
7. Click the **Browse** button and select the first file obtained in step 2.
8. Click the **Download** button.
9. When the download is complete, press the **OK** button.
10. Repeat steps 7, 8 and 9 with the second and third files obtained in step 2.
11. When all three banks are downloaded, click the **Start Programs** button.

This completes the installation of camera specific software and firmware. The next thing to do is to configure the iRIS to take images.

² See iRIS320 User Guide for more information on the logger to PC connections.

³ See the iLink manual for information on how to connect to data loggers.

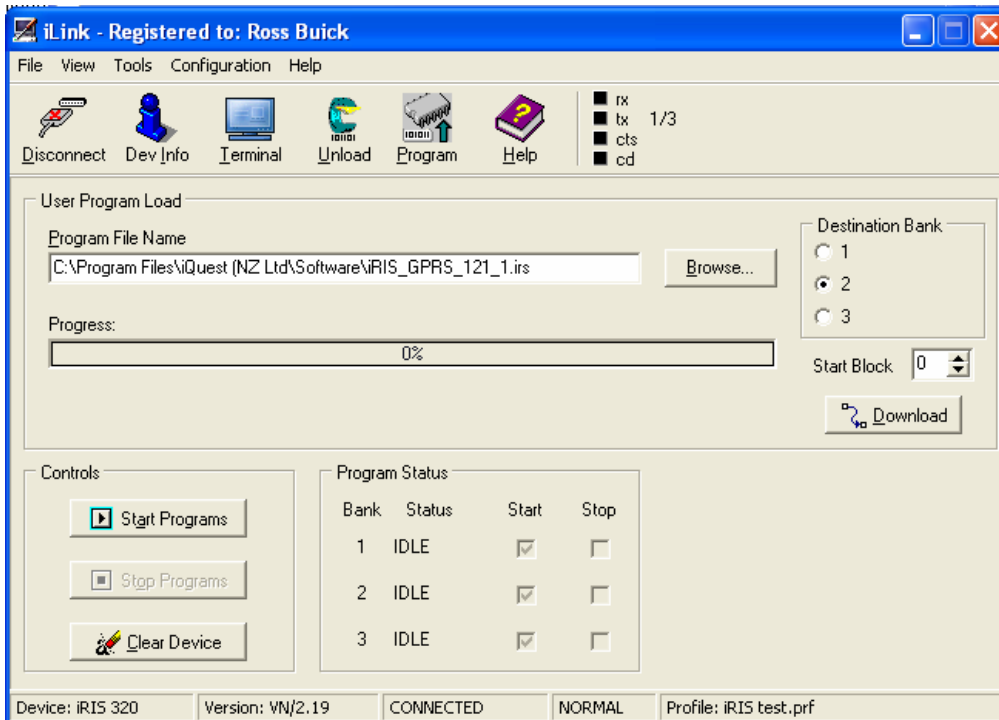

Figure 2 The programming window of the iLink Software Package.

5.1.2 Configure the Camera on the IRIS320

As with a standard iRIS data logger all configuration is achieved through a terminal session with the logger from a PC. This is done by connecting a PC to the logger with a null modem cable and connecting to it with a terminal program like HyperTerminal⁴. The list below describes the configuring of the settings that relate to the operation of the camera.

Camera Menu

1. If not already connected, connect to logger using HyperTerminal with communication settings 38400,N,8,1.⁵
2. When the main menu is shown choose menu item 9 Camera, which will display the following menu.

```
* Camera Cfg
0 Exit
1 Resolution [7: 640x480]
>
```

3. Use menu item 1 Resolution to adjust the resolution that pictures will be taken at when in scheduled mode. Options are:
 - 0: disabled
 - 1: 80x64
 - 3: 160x128
 - 5: 320x240 (QVGA)
 - 7: 640x480 (VGA)
4. Select menu item 0 Exit to return to the main menu.

⁴ Please see the iRIS 320 User Guide for information regarding connections and HyperTerminal Settings.

⁵ If the camera is currently taking a picture, the RS232 port used by the PC will be disabled. This will cause a connection error from iLink. Please wait 30 seconds and retry.

There are two ways of taking an image:

- Scheduled – This method uses the Digital Output #1 schedule control to take pictures at regular intervals. Digital Output #1 is still triggered on the schedule, which means it can be used to control external illumination for the camera.
- Remote – Use HydroTel™ to start a picture capture. Refer to the HydroTel documentation on how to setup and use this feature.

Scheduled Picture Capture Settings

1. Connect to logger using HyperTerminal with communication settings 38400,N,8,1.⁶
2. When the main menu is shown choose menu item 5 `Outputs`, which will display the outputs menu.
3. Select menu item 1 `Output #1`, which will display the following menu.

```
* Digital Output 1 Cfg
0 Exit
1 Enable [Yes]
2 Polarity [Normal]
3 Mode [1: Schedule]
4 Duration [10 sec]
5 Frequency [15 min]
6 Start Time [0525]
7 End Time [1959]
>
```

4. The important settings are as follows
 - Menu item 1, Yes.
 - Menu item 3, 1: Schedule.
 - Menu item 4, 10 seconds.
 - Menu item 5, how often the images are taken in minutes.
 - Menu item 6, start taking images at this time (24 hour clock).
 - Menu item 7, stop taking images at this time (24 hour clock).

Remote Picture Capture Settings

In this mode the iRIS-CAM will take a picture on request from base. There are no iRIS based settings required for this mode, picture capture will happen automatically and can be used in conjunction with schedule mode. Note: Resolution of the remote picture can be different to the scheduled one.

⁶ If the camera is currently taking a picture, the RS232 port used by the PC will be disabled. This will cause a connection error from iLink. Please wait 30 seconds and retry.